

ASSEMBLY INSTRUCTION

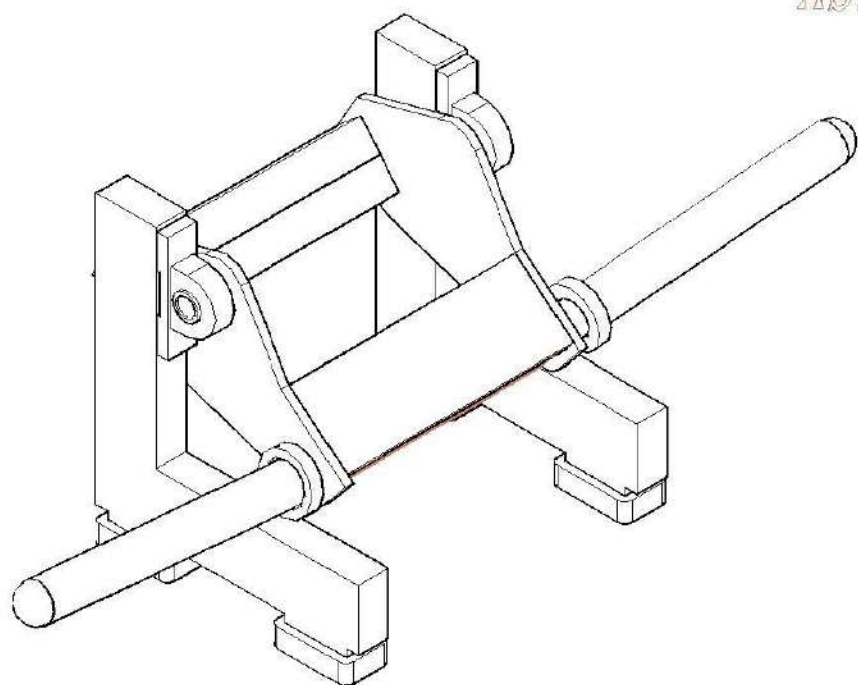

*Tibia Dorsal Flexion
HS-103*

SHAN DONG REALLEADER FITNESS CO., LTD

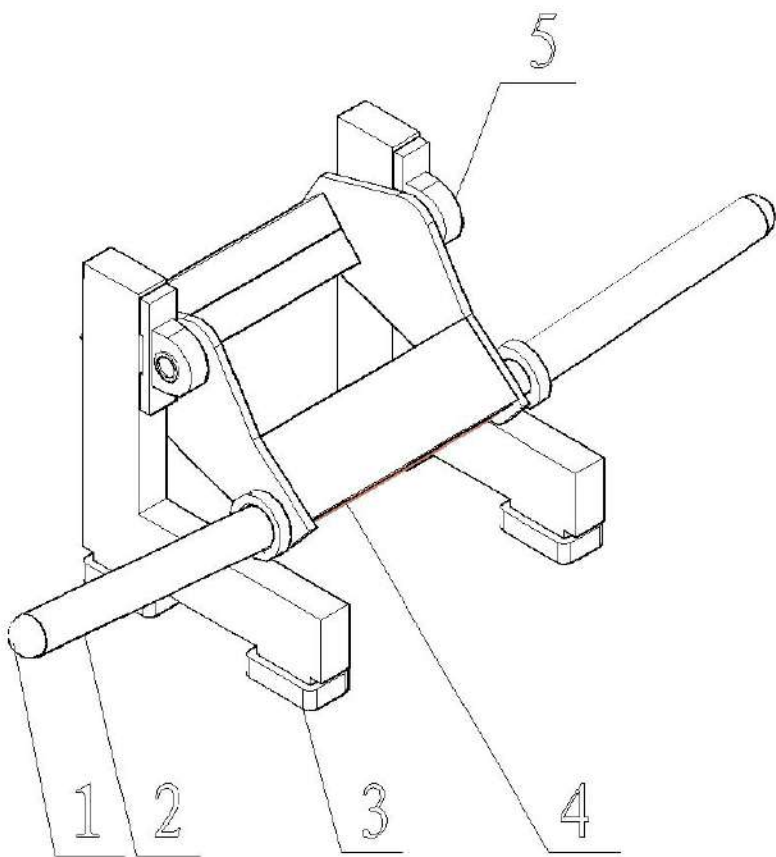

1 Cap of Barbell Sleeve

2 Barbell Sleeve

3 Rubber Shoe

4 Pad

5 Bearing Block